

## (4.1) MECH MPG COUPLER OPERATION - To Attach

**!WARNING** - The operator should be familiar with the correct use of the coupler before operating the machine.

**!WARNING** - Place the coupler decal in the machine cab where it can be seen clearly. Replace unreadable or missing decals with new ones before operating the machine.

**!WARNING** - Never operate the coupler without the safety pin in place.

1. Ensure the coupler safety pin is removed. Place the coupler above the bucket/attachment.



fig 4.8

2. Engage the coupler onto the front bucket pin.



fig 4.9

3. Extend the bucket cylinder until the coupler is positioned correctly on to the bucket.



fig 4.9

4. Place the toggle bar on the hexagonal nut and turn anti-clockwise to engage the hook (fig 4.9). Visually inspect to ensure the hook is fully retracted (fig 4.10).

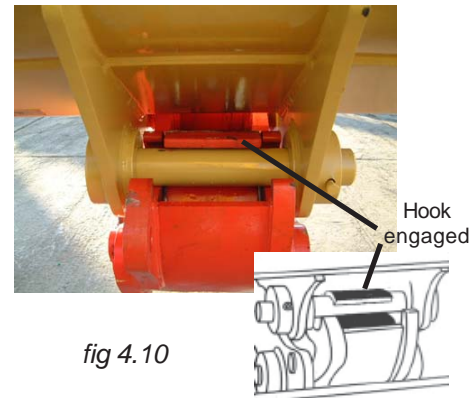

fig 4.10



fig 4.11

5. Once the hook is engaged replace the locking cap on to the coupler as shown above.



fig 4.12



fig 4.13

6. The manual back up safety pin must now be fitted (fig 4.12). The coupler frame is a multi-hole design **see section for correct hole choice**. The safety pin must be fitted by hand pressure only, not hammered or forced into position. Insert the lynch pin into the end of the safety pin to secure it (fig 4.13).

## MECH MPG COUPLER OPERATION

### - To Release

 **WARNING** - Do not try to release or change the bucket near any persons or in any areas that may result in an accident or injury occurring.

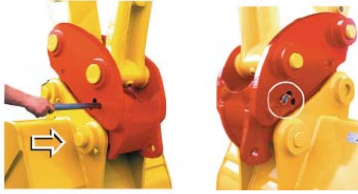

fig 4.14

fig 4.15

1. Place the bucket on the ground and remove the lynch pin (fig 4.14) and then the safety pin (fig 4.15)



fig 4.16

2. Now remove the locking cap from the coupler.



3. Place the toggle bar on the hexagonal nut and turn clockwise to engage the hook (fig 4.17). Visually inspect to ensure the hook is fully retracted (fig 4.18).

